



**ARTICULATING &
TELESCOPIC BOOMS
ALL-TERRAIN DIESEL**

**RTJ PRODUCT LINE
16 TO 28 METERS**





haulotte.com

Haulotte 
EQUIPMENT



CONTENTS

- APPLICATIONS..... 4**

- BENEFITS..... 7**
 -  **OPTIMAL SAFETY..... 8**
 -  **OUTSTANDING PRODUCTIVITY 12**
 -  **EXCELLENT ALL-TERRAIN CAPACITIES 15**
 -  **SUSTAINABLE DESIGN 18**
 -  **MAXIMIZED UPTIME 21**

- MODELS & OPTIONS..... 24**



With more than 30 years of experience designing booms, Haulotte is no stranger to the obstacles associated with operation and fleet management.

Our RTJ range of articulating and telescopic booms is designed to work in the most restrictive environments and tackle the most demanding projects.

RTJ booms incorporate our latest innovations to offer you the safest solutions on the market for working at heights, increase the productivity of your construction sites and optimize the uptime of your machines.

TAKE ADVANTAGE OF
HAULOTTE EXPERTISE

APPLICATIONS

OPT FOR **VERSATILITY**



CONSTRUCTION: BUILDING SHELL

Structural steel, siding, masonry, etc.



CONSTRUCTION: FINISHING

Electrical, HVAC, insulation, painting, etc.

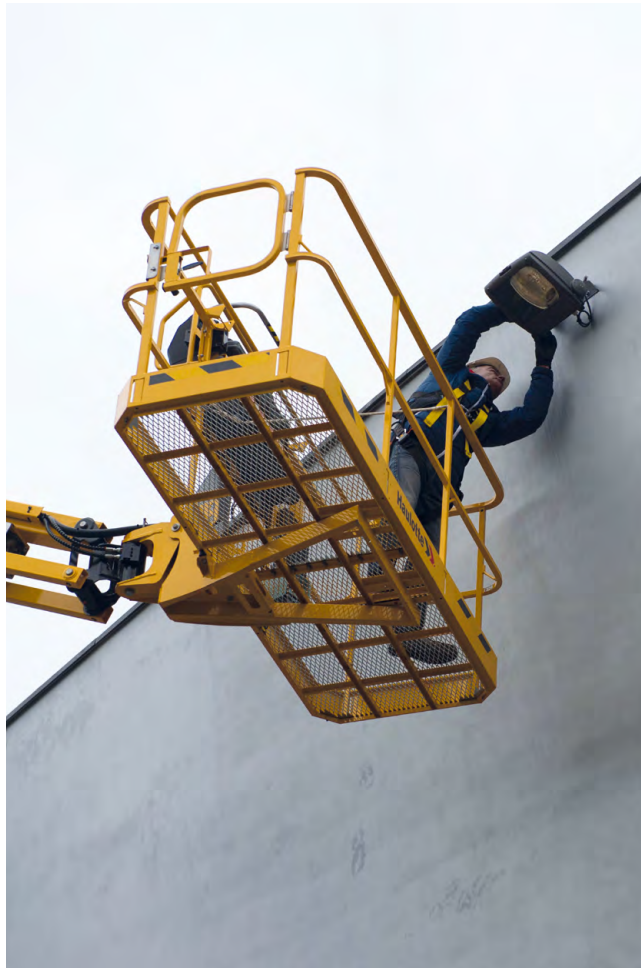

MAINTENANCE AND UPKEEP

Plumbing, electrical, industrial cleaning, etc.

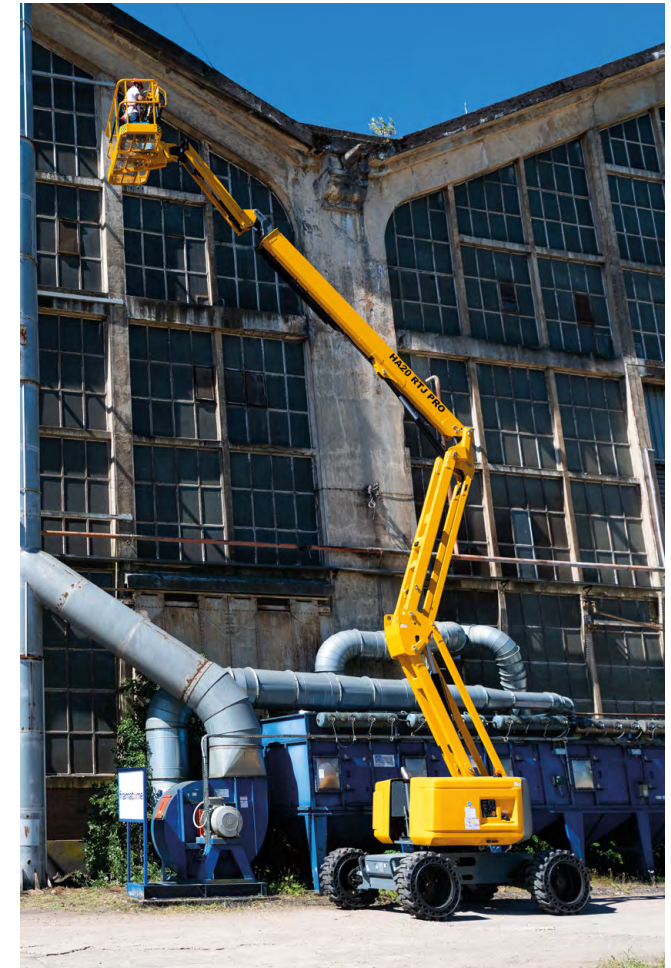

APPLICATIONS

OPT FOR **VERSATILITY**



SPECIFIC INDUSTRIAL OPERATIONS

Mining, airport applications, etc.



LANDSCAPING AND TREES



EVENTS

Concert halls, stadiums, etc.

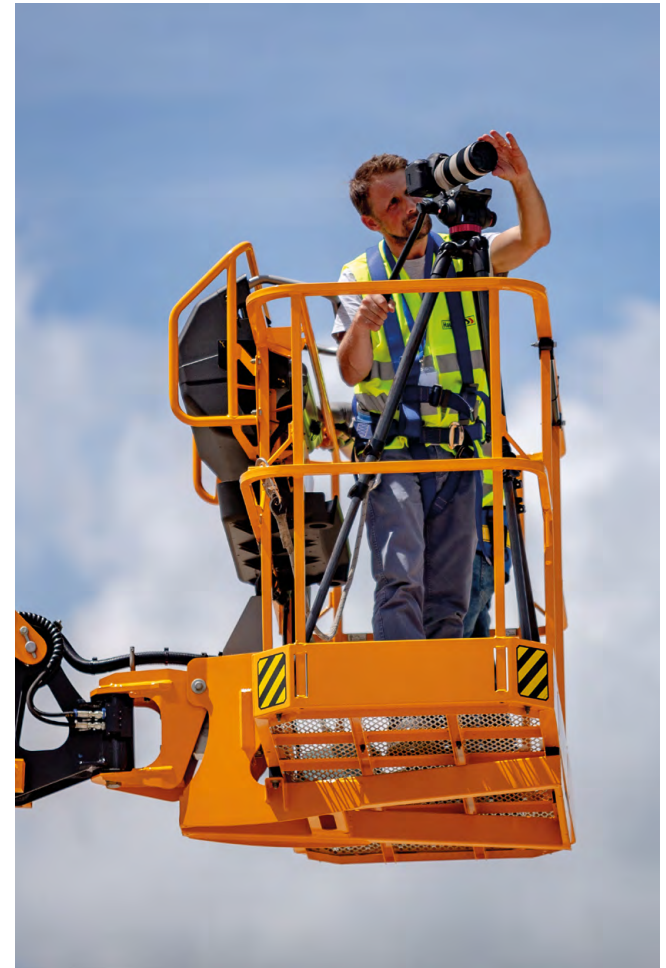



TELESCOPIC BOOMS

Telescopic architecture allows for straight and direct elevation.

Benefits:

- > **Extended horizontal outreach** for access to the most remote work areas.
- > **Ease of use** for greater efficiency.



ARTICULATED BOOMS

The articulating architecture features a boom arm with a pivot point.

Benefits:

- > **Ability to extend above obstacles** to reach the most inaccessible work areas.
- > **Work in highly confined areas** thanks to a more compact architecture.

CHOOSE THE RIGHT ARCHITECTURE

Designed to operate anywhere, even on the roughest terrain, Haulotte diesel articulating and telescopic booms offer a number of shared benefits. The most suitable architecture for you depends on the layout of your work area.

BENEFITS

GET THE BEST FROM THE RTJ RANGE



OUTSTANDING PRODUCTIVITY

- > Dual load capacity
- > Rapid, simultaneous movements
- > 360° continuous rotation
- > Better working envelope



OPTIMAL SAFETY

- > Haulotte Activ'Shield Bar 2.0 prevents crushing risks
- > Haulotte Activ'Lighting System ensures safety during nighttime loading and unloading operations
- > Proportional movements for greater precision and safety



EXCELLENT ALL-TERRAIN CAPACITIES

- > 4-wheel steering / 4-wheel drive
- > Oscillating axle
- > Up to 45° slope climbing capacity



MAXIMIZED UPTIME

- > Haulotte Activ'Screen: on-board intuitive diagnostic interface
- > Haulotte Diag: wireless configuration and diagnostics
- > Easy access to components



SUSTAINABLE DESIGN

- > Haulotte Stop Emission System reduces engine and component use
- > Impact protection for exposed components

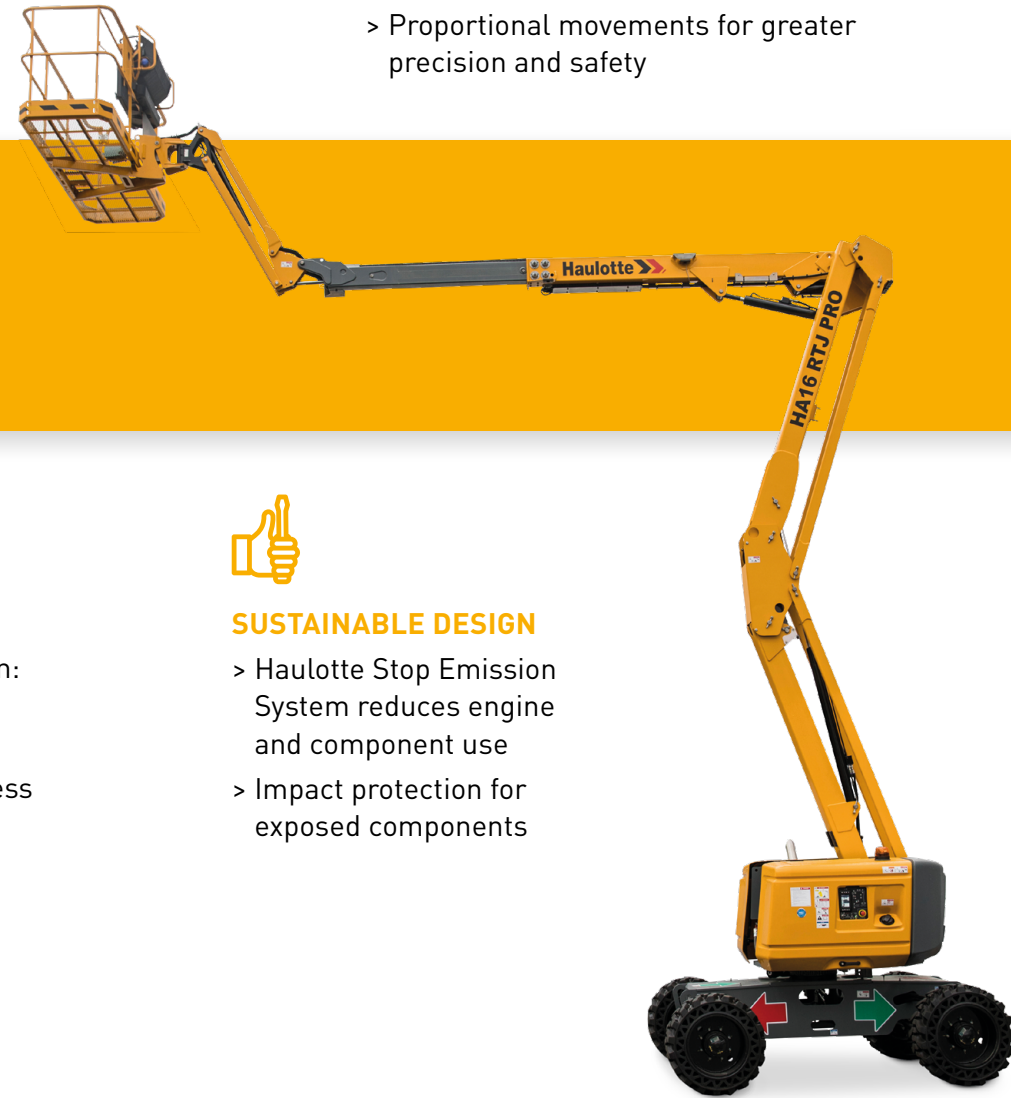

OPTIMAL SAFETY



**OPTIMAL
SAFETY**

WORK IN COMPLETE **SAFETY**

Our teams go beyond mere compliance with regulatory standards, constantly innovating to offer the safest machines on the market.

PRECISE MOVEMENTS

Proportional controls ensure precise movements, guaranteeing smooth operation on the way up to the work area. No jolts, just fluid motion.



**AT HAULOTTE,
OPERATOR SAFETY IS OUR
NUMBER ONE PRIORITY**



OPTIMAL SAFETY



WORK IN COMPLETE SAFETY

Haulotte 
ACTIV' SHIELD
B A R

EXCLUSIVE TECHNOLOGY

SECONDARY GUARDING DEVICE

Haulotte Activ'Shield Bar 2.0 is by far the safest and most effective system of its kind. Faced with a risk of entrapment, the operator is propelled against the bar. The machine automatically stops. Protected by the Safety Gap, the operator maintains easy access to controls with unobstructed visibility.



BUFFER ZONE

to prevent inadvertent activation.



STOP POSITION

to immediately stop the machine. Only safe movements intended to move away from the obstacle remain possible.



SAFETY GAP

with wide clearance of the bar to prevent driver entrapment and enable the driver to adopt a safe position inside the basket if necessary.



**OPTIMAL
SAFETY**



Illuminated controls
on the upper and
lower control box



Automatic activation with
the twilight sensor



Illuminated area
around the machine

SAFE OPERATIONS IN LOW VISIBILITY CONDITIONS

Haulotte 
**ACTIV' LIGHTING
SYSTEM**

EXCLUSIVE TECHNOLOGY

ULTRA-HIGH-PERFORMANCE LIGHTING SYSTEM

Booms are generally loaded and unloaded early in the morning or in the evening. To ensure safe performance of these delicate procedures, RTJ models feature the innovative high-performance Haulotte Activ'Lighting System.

Comprising 10 LED spotlights, it provides ideal illumination of the basket, controls and the maneuvering area around the machine.

OUTSTANDING **PRODUCTIVITY**



**OUTSTANDING
PRODUCTIVITY**

BOOST YOUR PRODUCTIVITY



**QUICK AND EASY
ACCESS TO THE
WORK AREA**

BETTER WORKING ENVELOPE

Featuring the best working envelope on the market, RTJ booms let you reach the most inaccessible areas. On articulating booms, the height of the up and over clearance makes it possible to clear even the highest obstacles.

SIMULTANEOUS MOVEMENTS AND 360° ROTATION

Ultra-fast elevation speed combined with simultaneous movement controls and 360° turret rotation let you reach the work area quickly for greater efficiency.



**OUTSTANDING
PRODUCTIVITY**





**BOOST
YOUR
PRODUCTIVITY**

**EXAMPLE OF WORKING
ENVELOPE WITH DUAL-LOAD
CAPACITY**

Haulotte 
DUAL LOAD

EXTENDED LOAD CAPACITY

Many applications require heavy equipment. To reduce the number of trips between the ground and the work area, the dual-load option increases the basket load capacity. The working envelope is reduced during dual-load operation to guarantee machine stability.

-  Nominal load capacity
-  Load capacity increased by an additional 100 to 220 kg*

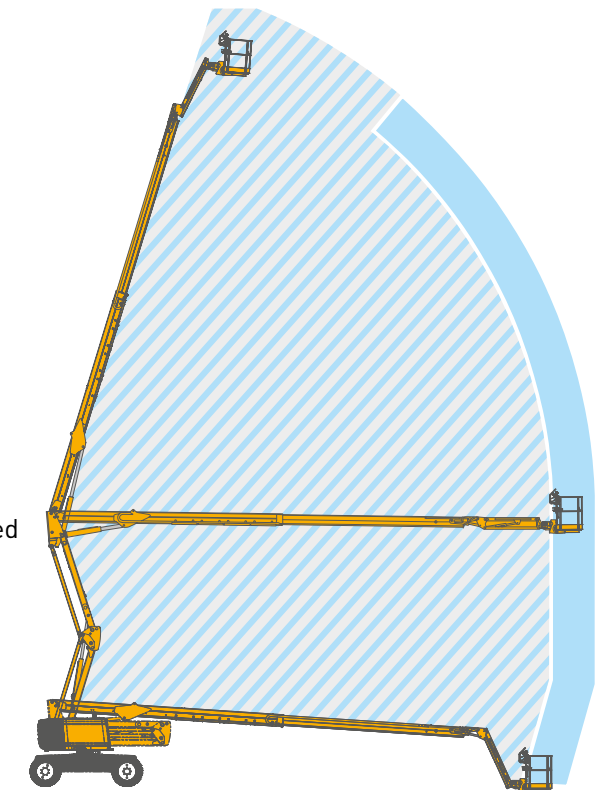

*Information on extended load capacity for specific machines on page 26

EXCELLENT
ALL-TERRAIN
CAPACITIES



**OUTSTANDING
ALL-TERRAIN CAPACITY**

ENJOY **EXCEPTIONAL** DRIVABILITY



Solid cured-on tires

Oscillating axle

RTJ models always feature 4-wheel drive to operate anywhere, even on the roughest terrain.

EXCELLENT TERRAIN FOLLOWING

- > **The oscillating axle** adjusts the position of the axle to adapt to the terrain and keep the wheels in contact with the ground,
- > **The solid cured-on tires*** are extremely sturdy, hugging the ground and absorbing shocks. They are also available in markless version for use on sensitive floors or those whose appearance require special care,
- > **The limited-slip differential** adjusts the speed of each wheel, preventing the loss of traction...

...ON LOW TRACTION SURFACES...

- > **The differential lock** offers additional traction on loose or slippery surfaces by locking the differential. Power is transmitted to each wheel to power the machine through challenging terrain.

* The HT23 model is equipped with foam-filled tires



**OUTSTANDING
ALL-TERRAIN CAPACITY**



**DIFFERENT
STEERING
MODES TO SUIT
ANY SITUATION**

Enjoy greater agility thanks to 4-wheel steering:

> **In 4-wheel steering mode**, the turning radius is shortened, enabling you to maneuver in tight or congested spaces.

**SUPERIOR
DRIVABILITY**

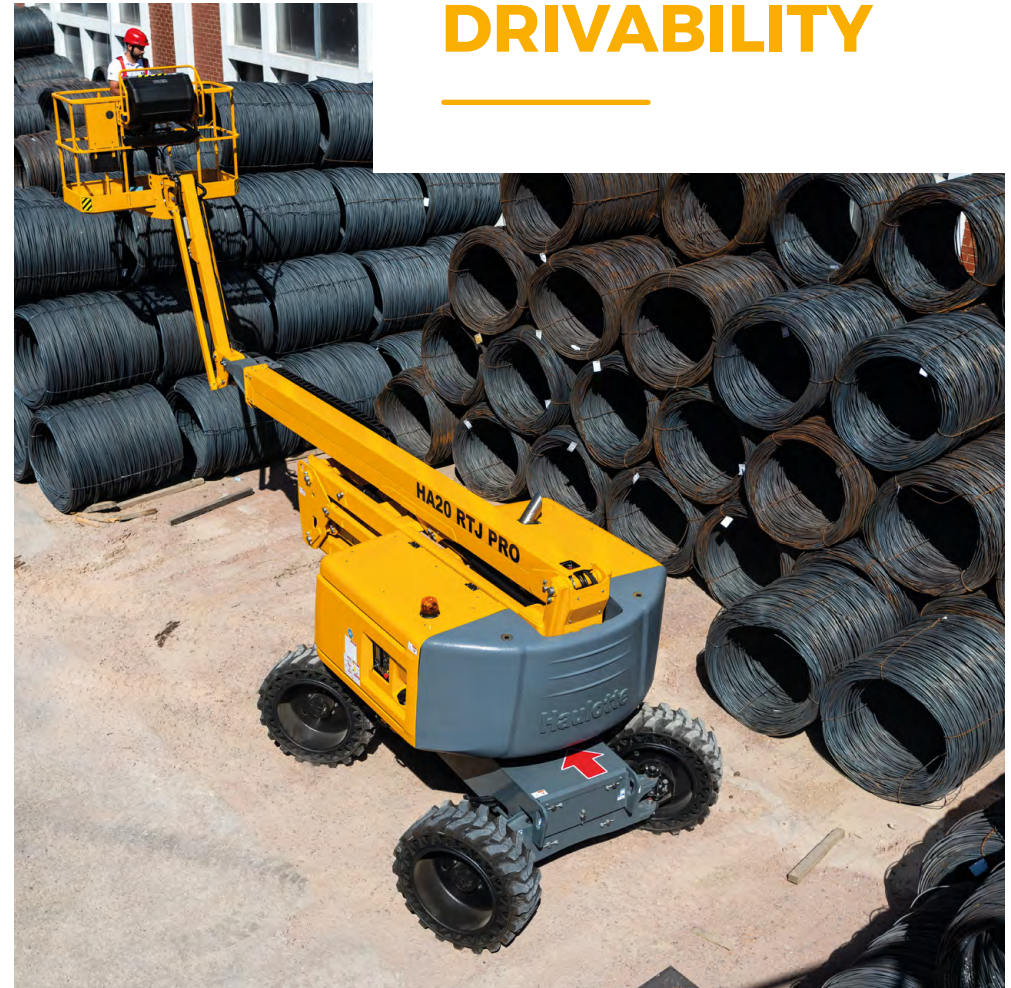

> **Crab steering** lets you move in any direction, making it easier to access the work area.

SUSTAINABLE DESIGN



**SUSTAINABLE
DESIGN**



OPTIMIZE YOUR TOTAL COST OF OWNERSHIP

When operators are working at heights, booms may remain immobile for several hours.

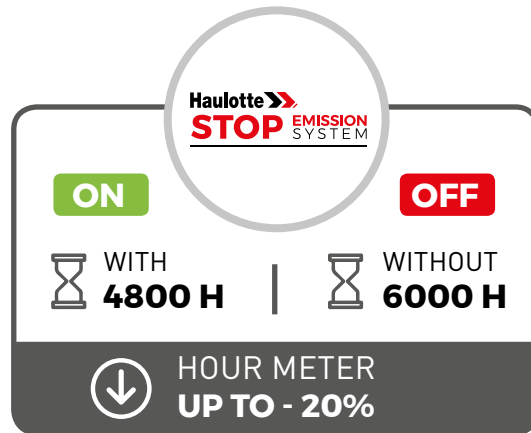

Haulotte **STOP** EMISSION SYSTEM

EXCLUSIVE TECHNOLOGY

START & STOP SYSTEM

The RTJ range is equipped with the Haulotte Stop Emission System, which automatically stops the engine after a period of idle running. The engine instantly restarts when the operator performs an action.

OPTIMIZED TOTAL COST OF OWNERSHIP

- > Use of the engine and peripheral components reduced by up to 20%,
- > Lower fuel consumption,
- > Longer intervals between maintenance,
- > Greater residual value.

RESPECTFUL OF THE ENVIRONMENT AND PEOPLE NEARBY

- > Reduced air and noise pollution,
- > Greater comfort for people living or working in the area.



SIMPLIFY MAINTENANCE OPERATIONS

Components requiring regular maintenance are easily accessible, thus making maintenance operations simple and less time-consuming.



Swing out engine tray for access to the batteries and oil filter

Coolant tank

Air filter

Fuel filter

Battery

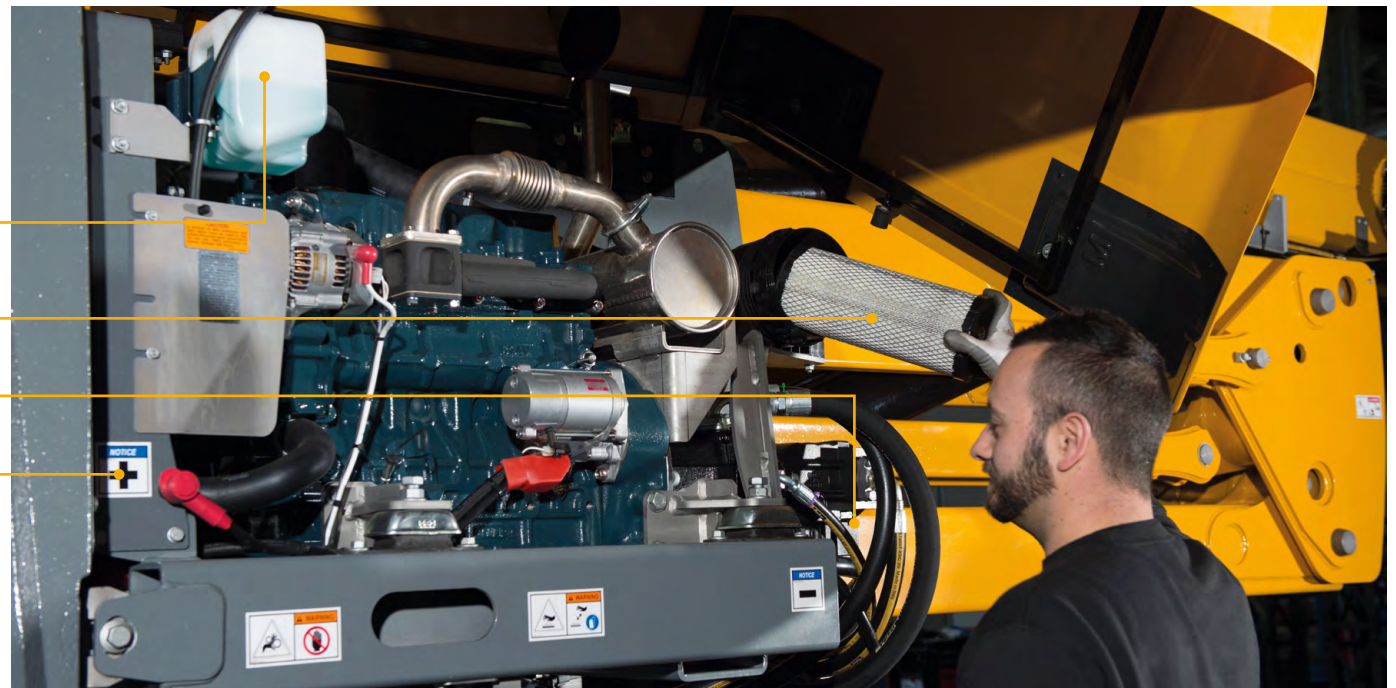

MAXIMIZED UPTIME

24 MAXIMIZED UPTIME

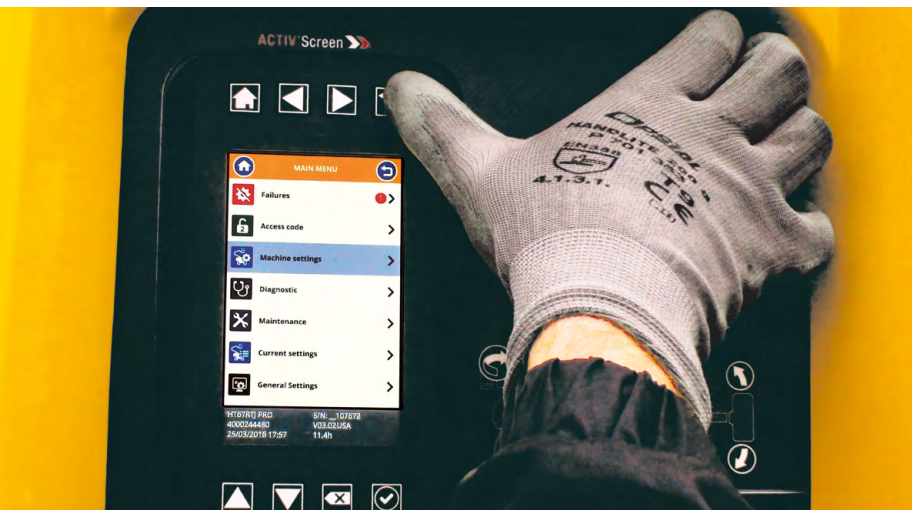

MAXIMIZE THE UPTIME OF YOUR FLEET

Haulotte 
ACTIV' SCREEN

EXCLUSIVE TECHNOLOGY

ON-BOARD CONFIGURATION AND DIAGNOSTIC TOOL

Haulotte Activ'Screen makes life easier for users and technicians on a daily basis, providing access to:

- > Machine configuration,
- > Information on machine functioning (tilt sensing, overloading, fuel level),
- > Preventative maintenance operations,
- > Diagnosis of malfunctions and instructions for resolution.



ALL FUNCTIONS AVAILABLE ON THE GO



All Haulotte Activ'Screen functions are available on the mobile app: Haulotte Diag. Technicians enjoy wireless mobility for conducting more effective configuration and diagnostics.

WORK IN THE MOST RESTRICTIVE ENVIRONMENTS



ULTRA-DURABLE PROTECTIVE HOUSING AND TOOL TRAY made of composite material



REINFORCED TURRET HOODS with metal support framework



ANTICORROSION TREATMENT on axles, fasteners and painted components. Built to withstand 500h salt spray test



LOAD SENSING SYSTEM PROTECTED within the platform yoke assembly

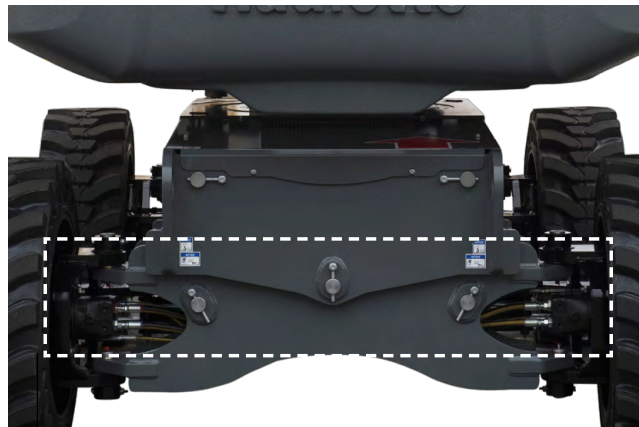

STEERING CYLINDERS PROTECTED inside the frame



BOOM PROTECTED by the counterweight frame

MODELS & OPTIONS

MODELS & OPTIONS

DESIGNED
TO MEET
**YOUR EVERY
NEED**

EVERY CONSTRUCTION
SITE IS UNIQUE.
THAT'S WHY HAULOTTE
OFFERS A WIDE RANGE
OF MODELS AND
EQUIPMENT

Haulotte

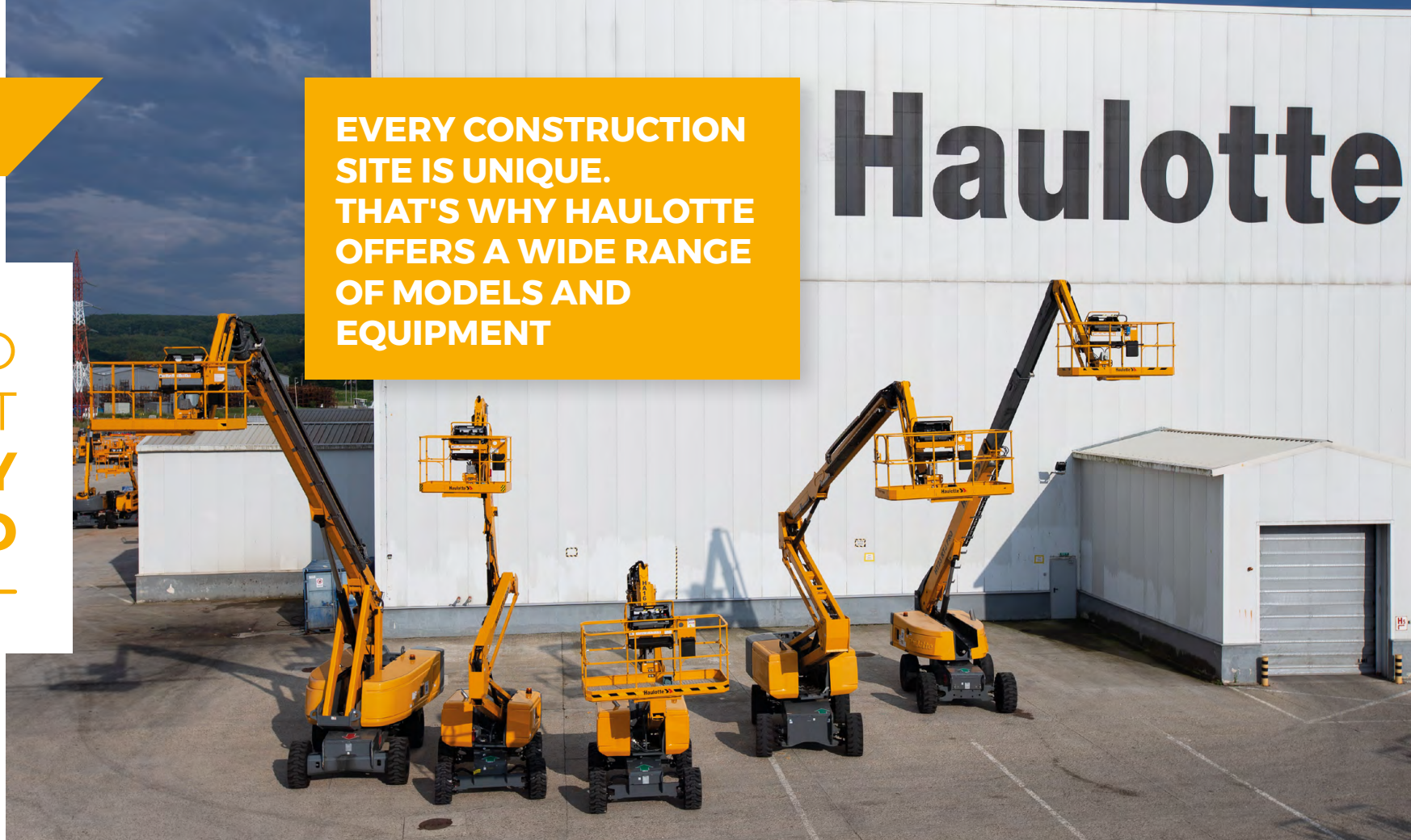

5 MODELS

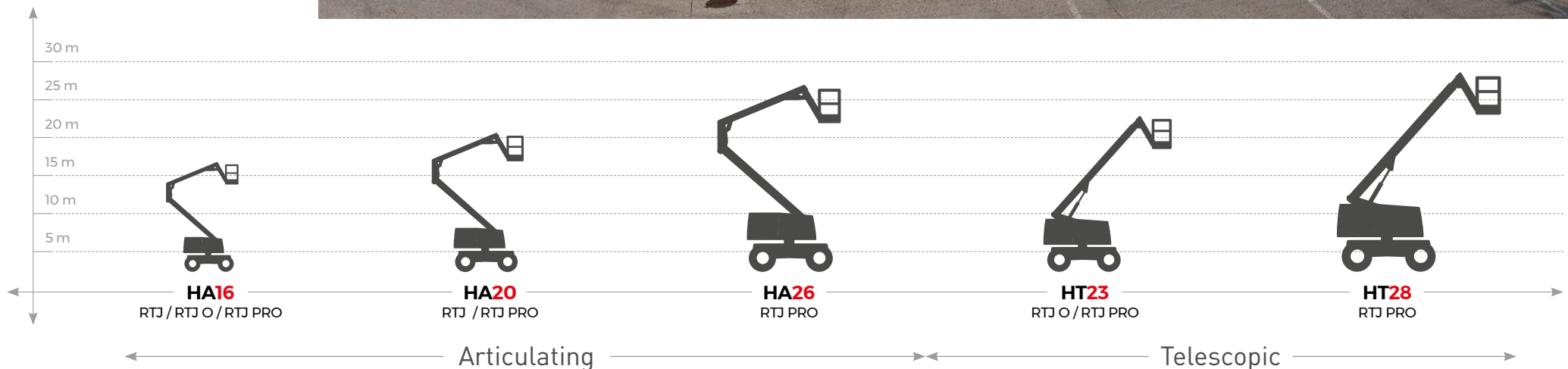

Availability of models may vary by region. Please contact your Haulotte representative.

CHOOSE THE VERSION BEST SUITED TO YOUR NEEDS

		HA16			HA20		HA26	HT23		HT28
		RTJ	RTJ O	RTJ PRO	RTJ	RTJ PRO	RTJ PRO	RTJ O	RTJ PRO	RTJ PRO
CAPACITY	Working height	16 m			20.6 m		26.4 m	22.5 m		27.9 m
	Up and over clearance	7.65 m			8.4 m		9.3 m	-		-
	Maximum outreach	8.3 m			12.2 m		17.5 m	18.3 m		23.9 m
	Basket load capacity	230 kg 2 pers.			230 kg 2 pers.		250 kg 2 pers.	230 kg 2 pers.		230 kg 2 pers.
	Dual-load	-			-		○ 350 kg 2 pers.	○ 450 kg 3 pers.		○ 350 kg 2 pers.
	Maximum wind speed	60 km/h			60 km/h		45 or 60 km/h	45 or 60 km/h		45 or 60 km/h
EQUIPMENTS	Wheel-steer	2	2	4	2	4	4	2	4	4
	Tires	Solid			Solid		Solid	Foam-filled		Solid
	Oscillating axle	○	●	●	○	●	●	●	●	●
	Turret rotation	355°	355°	360° cont.	355°	360° cont.	360° cont.	360° cont.	360° cont.	360° cont.
	Jib	●	●	●	●	●	●	●	●	●
INNOVATIONS	Activ'Shield Bar 2.0	○	○	●	○	●	●	○	●	●
	Activ'Lighting System	○	○	●	-	-	●	○	●	●
	Activ'Screen	●	●	●	●	●	●	●	●	●
	Stop Emission System	●	●	●	●	●	●	●	●	●

● Standard / ○ Option / - Not available

MODELS & OPTIONS



CHOOSE THE
EQUIPMENT
SUITED
TO YOUR
BUSINESS



CUSTOMIZE THE MODEL TO SUIT YOUR ENVIRONMENT

- > Cold & Arctic weather package
- > Warm weather package
- > Anti-overspeed kit
- > Non-marking tires



INCREASE YOUR PRODUCTIVITY

- > Dual load capacity
- > Glazier pack
- > Pipe cradle
- > Compressed air line
- > 3.5, 6.5 or 12 kW hydraulic generator
- > AC power to platform



ENHANCE YOUR SAFETY AND COMFORT

- > Haulotte Activ'Lighting System
- > Haulotte Activ'Shield Bar
- > Strong wind package
- > Lateral swing door
- > Circuit breaker or ground fault interrupter

Availability of optional equipment varies by model.
Please contact your Haulotte representative.



HAULOTTE GROUP, La Péronnière - BP 9 - 42152 l'Horme - France
Tel: +33 (0)4 77 29 24 24 · Fax: +33 (0)4 77 29 43 95
haulotte@haulotte.com · www.haulotte.com

Haulotte 
LET'S DARE TOGETHER